

# BALL VALVES

KLINGER KHD-3-G-XC/RPTFE  
 Threaded ends, R or NPT-thread  
 full bore, PN50 / CL300

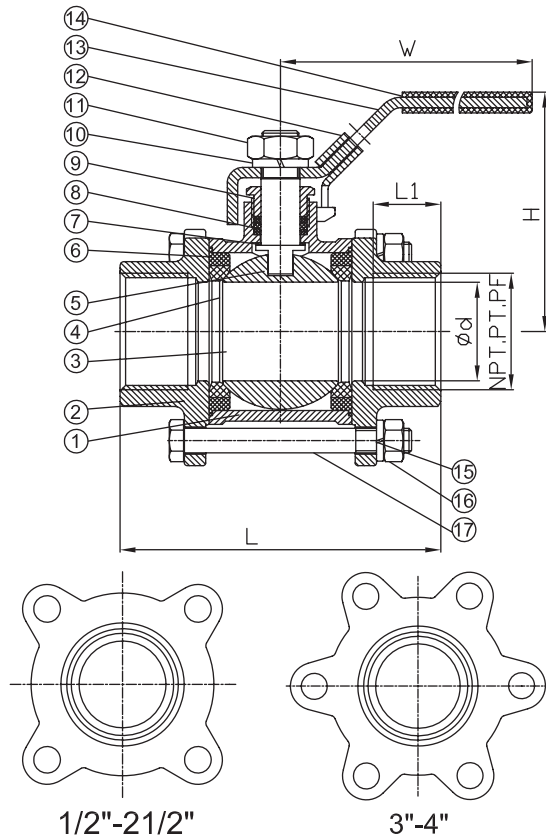

## PARTS

No.	Part	Material
1	Body	CF8M
2	End cap	CF8M
3	Ball	CF8M
4	Ball seat	R.PTFE*
5	Stem	AISI 316
6	Body Seal	PTFE
7	Thrust packing	PTFE
8	Stem packing	PTFE
9	Stem gland	AISI 304
10	Spring washer	AISI 304
11	Stem nut	AISI 304
12	Locking device	AISI 304
13	Handle	AISI 304
14	Sleeve	Vinyl
15	Spring washer	AISI 304
16	Nut	AISI 304
17	Bolt	AISI 304

\* 15% glass fibre

## DIMENSIONS AND WEIGHTS

DN	PN	d	L	L1	H	W	kg
10	50	12,7	60	10,0	54	102	0,3
15	50	15	64	11,5	62	123	0,5
20	50	20	71	13,0	66	123	0,6
25	50	25	82	14,5	77	153	0,9
32	50	32	97	17,0	80	153	1,3
40	50	38	109	17,0	91	183	2,0
50	50	50	125	21,5	98	183	3,1
65	50	65	162	23,5	138	246	6,5
80	50	80	175	26,5	154	246	9,7
100	50	100	216	32,5	175	350	16,5

## MAX. TEMPERATURE / PRESSURE

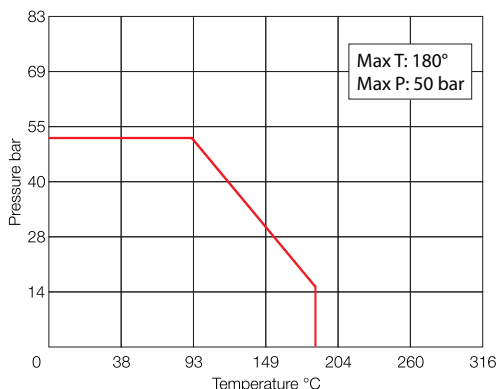

## STANDARDS AND CERTIFICATION

- » PED 2014/68/EU
- » Pressure test EN 12266-1, API 598
- » EN 10204 Certificate (3.1)

## APPLICATIONS

For general use. Not for abrasive or crystallizing media.